

# Transmission Line Foundation Design

## Design Standard

### DOCUMENT HIERARCHY

This document resides within the Planning component of Western Power's Asset Management System (AMS).

### DOCUMENT DATE

This document was last updated September 2023

### IMPLEMENTATION DATE

This document came into service September 2020

### DOCUMENT CONTROL

Record of endorsement, approval, stakeholders, and notification list is provided in EDM#34135372 appendix

### RESPONSIBILITIES

Western Power's Engineering and Design Function is responsible for this document

### CONTACT

Western Power welcomes your comments, questions, and feedback on this document, which can be emailed to [standards.excellence@westernpower.com.au](mailto:standards.excellence@westernpower.com.au)

### DISCLAIMER

This document is published by Western Power for information purposes only. The user must make and rely on their own inquiries as to the quality, currency, accuracy, completeness, and fitness for purpose of any information contained in this document. Western Power does not give any warranty or make any representation concerning the information provided in this document. By using the information in this document, the user acknowledges that they are solely responsible for obtaining independent professional advice prior to commencing any project, activities, or other works. Western Power is not liable in any way for any loss, damage, liability, cost or claim of any kind whatsoever (including responsibility by reason of its negligence) arising from or in connection with the use of or reliance on the information contained in this document. Western Power reserves its rights to modify, supplement or cancel this document or any part thereof at any time and without notice to users.

### COPYRIGHT

© Copyright 2022 Electricity Networks Corporation trading as Western Power. All rights reserved. No part of this work may be reproduced or copied in any form or by any means without the written permission of Western Power or unless permitted under the Copyright Act 1968 (Cth). Product or company names are trademarks or registered trademarks of their respective holders

© Western Power  
ABN 18540492861

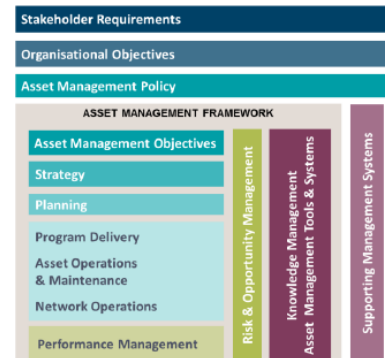

# Contents

<b>Contents .....</b>	<b>2</b>
<b>Revision Details.....</b>	<b>5</b>
<b>1. Introduction .....</b>	<b>6</b>
1.1 Purpose and scope .....	6
1.2 Acronyms .....	7
1.3 Definitions .....	7
1.4 References .....	7
<b>2. Safety in Design.....</b>	<b>8</b>
<b>3. Compliance .....</b>	<b>9</b>
<b>4. Functional Requirements.....</b>	<b>9</b>
<b>5. Design Procedure .....</b>	<b>10</b>
5.1 Design Actions.....	10
5.2 Design Equation .....	10
5.3 Design Revisions.....	10
5.4 Geotechnical Strength Factors.....	10
<b>6. Materials and Durability.....</b>	<b>10</b>
6.1 Property of materials .....	10
6.1.1 Steels .....	10
6.1.2 Concrete .....	11
6.1.3 Timbers.....	11
6.2 Durability requirements.....	11
6.2.1 Steels .....	11
6.2.2 Concrete .....	11
6.2.3 Timbers.....	12
6.2.4 Sections buried in Ground .....	12
<b>7. Tower Foundations .....</b>	<b>12</b>
7.1 Tower Foundations Classifications.....	12
7.2 Summary of Foundation types.....	17
7.3 Geotechnical Design of Bored Foundations.....	18
7.3.1 Bored Undercut Foundation Uplift Capacity .....	18
7.3.2 Bored Undercut Foundation Compression .....	19
7.3.3 Bored Socketed Foundation Uplift Capacity .....	20
7.3.4 Bored Socketed Foundation Compression Capacity.....	20

7.3.5	Effects of Liner on Bored Foundation (Type A, B, D) .....	21
7.4	Geotechnical Design of Mass Concrete Foundation .....	21
7.4.1	Mass concrete undercut Uplift Capacity .....	21
7.4.2	Mass concrete undercut Compression Capacity .....	21
7.4.3	Mass Concrete without Undercut uplift capacity.....	22
7.4.4	Mass Concrete without Undercut Compression Capacity .....	22
7.4.5	Mass Concrete under Bending and Compression.....	23
7.5	Geotechnical of Piled Foundation.....	23
7.6	Steel Grillages.....	23
7.7	Soil Lateral Capacity .....	23
7.8	Design for combined load .....	23
7.9	Stability of Slopes.....	23
7.10	Structural Design of foundation Elements.....	24
7.10.1	Design of Studs and Cleats.....	24
7.10.2	Bored Columns or Chimneys of Mass Concrete .....	24
7.10.3	Extensions.....	25
7.10.4	Slabs and Beams .....	25
7.10.5	Pile Caps .....	26
7.10.6	Driven Piles.....	26
7.11	Design For Serviceability .....	26
7.11.1	Foundation Movements.....	26
7.11.2	Differential Settlements .....	26
7.11.3	Constructability .....	27
<b>8.</b>	<b>Pole Foundations.....</b>	<b>27</b>
8.1	General.....	27
8.2	Types of Pole Foundations.....	27
8.3	Direct Buried Pole Embedment Depth.....	29
8.3.1	Timber Poles .....	29
8.3.2	Other Poles .....	30
8.3.3	Water Table .....	31
8.3.4	Sloping Ground .....	31
8.4	Excavation and Underground Services .....	33
8.5	Design of Foundation Elements .....	33
8.5.1	Design of Concrete Footings .....	33
8.5.2	Design of Ground Stay Anchors .....	33

8.5.3	Design of Steel Elements .....	34
8.6	Design for Serviceability.....	36
8.6.1	Foundation Rotations .....	36
8.6.2	Preset .....	36
8.6.3	Settlements .....	37
8.6.4	Constructability .....	37
<b>9.</b>	<b>Backfill and Concrete Encasement .....</b>	<b>38</b>

## Revision Details

Version	Date	Summary of change	Section
0	01/09/2020	Initial release	
1	01/09/2023	Change to AMS format	

## 1. Introduction

This standard specifies the design requirements for Western Power high voltage overhead transmission line foundations in terms of satisfactory compliance with relevant Australian and International Standards.

### 1.1 Purpose and scope

This standard applies to new transmission line constructions and when augmentation of existing transmission assets is required to meet the latest overhead transmission line design standards. It shall be read in conjunction with other Western Power design standards to form a complete design. The following classification of a transmission line components and elements applies:

**Table 1.1: Transmission Line System, Components and Elements**

Structural System	Components	Elements
Transmission Line	Supports	Steel, wood, concrete, composite
		Plates, bolts, nuts and washers
		Stays and fittings
		Top geometry
		Earthing and Insulations
	Foundations	Anchor bolts, steel piles and cleat angles
		Footings and soil
		Earthing systems
		Underground trenches
	Conductors	Wires
		Joints
		Hardware/ shackles
	Insulators	Insulator elements
		Brackets, bolts
		Fittings

This standard specifies the material and design (strength and durability) requirements for the elements of foundations as shown in shaded area of Table above.

## 1.2 Acronyms

Acronym	Definition
FPBW	Full Penetration Butt Weld
CPT	Cone Penetration Test
DCP	Dynamic Cone Penetrometer Test
ppm	Perth Sand Penetrometer Test
PSP	Perth Sand Penetrometer Test
SPT	Standard Penetration Test

## 1.3 Definitions

For the purpose of this standard, the definitions and notations given in AS/NZS 1170.2, AS/NZS 7000, ASCE/SEI 10-15, ASCE/SEI 48-11 and AS/NZS 4676 shall apply.

## 1.4 References

References which support implementation of this document

**Table 1.2 References**

Reference No.	Title
52539085	Hazards management register (HMR)
9009159	Design Standard - Transmission Line Geotechnical Investigations
9026775	Design Standard - Transmission Line Foundation Testing
8236837	Design Standard - Transmission Line Loadings and Support Structure Design
4469426	Full Length Preservative Treated Timber Poles
	The Electricity (Supply Standard and System Safety) Regulations 2001
AS/NZS 7000	Overhead line design – Detailed procedures
ASCE/SEI 10-15	Design of Latticed Steel Transmission Structures
ASCE/SEI 48-11,48-19	Design of Steel Transmission Pole Structures
AS 1289.0-7	Methods of testing soils for engineering purposes
AS 1604.1	Specification for preservative treatment – Sawn and round timber
AS 1720.2	Timber structures – Timber properties
AS 2082	Timber – Hardwood - Visually stress-graded for structural purposes
AS/NZS 2878	Timber – Classification into strength groups
AS 3818.11	Timber – Heavy structural products – Visually graded – Utility poles
AS 1012.1-21	Methods of testing concrete
AS 1289.5.2.1	Methods of testing soils for engineering purposes - Soil compaction and density tests - Determination of the dry density/moisture content relation of a soil using standard compactive effort

AS 1289.5.8.4	Methods of testing soils for engineering purposes - Soil compaction and density tests - Nuclear surface moisture-density gauges - Calibration using standard blocks
AS 1379	Specification and supply of concrete
AS 2758.1	Aggregates and rock for engineering purposes - Concrete aggregates
AS 3600	Concrete structures
AS 3610	Formwork for concrete
AS 3648	Specification and methods of test for packaged concrete mixes
AS 3972	General purpose and blended cements
AS/NZS 1252.1	High-strength steel fastener assemblies for structural engineering - Bolts, nuts and washers - Technical requirements
AS/NZS 1252.2	High-strength steel fastener assemblies for structural engineering - Bolts, nuts and washers - Verification testing for bolt assemblies
AS/NZS 1559	Hot-dip galvanized steel bolts with associated nuts and washers for tower construction
AS 2159	Piling – Design and installation
AS/NZS 2312.1	Guide to the protection of structural steel against atmospheric corrosion by the use of protective coatings - Paint coatings
AS/NZS 2312.2	Guide to the protection of structural steel against atmospheric corrosion by the use of protective coatings-Hot dip galvanizing
AS/NZS 3678	Structural steel – Hot rolled plates, floor plates and slabs
AS/NZS 3679.1	Structural steel – Hot rolled bars and sections
AS 4100	Steel Structures
AS/NZS 4671	Steel reinforcing materials
AS 4291.1	Mechanical properties of fasteners made of carbon steel and alloy steel - Bolts, screws and studs
AS/NZS 4680	Hot-dip galvanized (zinc) coatings on fabricated ferrous articles
	AASHTO LRFD Bridge Design Specifications
Eurocode 4:1994	Design of composite steel and concrete structures
IEEE 691 IEEE	Guide for Transmission Structure Foundation Design and Testing
	Main Road Specification 501
	Main Road Annexure 501A

## 2. Safety in Design

The foundation design must consider all safety aspects that can arise from the construction, operation, maintenance and decommissioning of the transmission line and other activities within the line corridor.

The *Transmission Line Foundation Design Hazard Management Register (HMR)*<sup>1</sup> captures and documents what risks have been controlled by this standard, and what residual risks may remain that should be considered at the project design stages and construction.

<sup>1</sup> See Western Power internal document



Every design is required to have its own project specific Hazard Management Register.

### 3. Compliance

All designs shall comply with the following standards as appropriate:

1. Electricity (Network Safety) Regulations 2015
2. AS 5577 Electricity network safety management systems
3. AS/NZS 7000 Overhead Line Design
4. AS 3818.11 Timber – Heavy structural products – Visually graded – Utility poles
5. AS/NZS 4677 Steel utility services poles
6. AS/NZS 4065 Concrete utility services poles
7. ASCE/SEI 10-15 Design of Latticed Steel Transmission Structures
8. ASCE/SEI 48-11,48-19 Design of Steel Transmission Pole Structures
9. AS 1720.1 Timber structures
10. AS 1379 Specification and supply of concrete
11. AS 2159 Piling – Design and installation
12. AS 3600 Concrete structures
13. AS 3610 Formwork for concrete
14. AS 4100 Steel Structures

### 4. Functional Requirements

The design of a transmission line system including the foundation shall be fit for purpose by incorporating the following aspects:

1. the electricity supply security and reliability level
2. constructability, durability, serviceability and maintainability
3. structural, electrical, mechanical and environmental performance
4. safety in design
5. value for investment (whole of life cost)

The functional requirements of transmission line structure foundations are:

1. safely transmit the load from tower/pole to the ground without excessive tower/pole deflection or settlement,
2. safely transmit fault current into the ground.

## 5. Design Procedure

### 5.1 Design Actions

Support structure foundations shall be designed to withstand ultimate and serviceability limit state load conditions in accordance with *Transmission Line Loadings and Support Structure Design Standard*<sup>2</sup>.

### 5.2 Design Equation

Foundations shall be designed by using a reliability based (risk of failure) approach. The performance of the foundation shall be evaluated for different circumstances using the limit state design equation:

$$\phi g R_n \geq S^*$$

Where:

$\phi g$  is the geotechnical strength factor.

$R_n$  is nominal strength of foundation.

$S^*$  is design action effect.

Foundations capacities shall be evaluated in accordance with Appendix L of AS/NZS 7000:2016 and the requirements specified in this standard. Soil properties selected for the design of the foundation shall be representative of the actual material upon which the foundation bears.

### 5.3 Design Revisions

When a foundation test is warranted, design inaccuracy revealed by the foundation test shall be corrected. Suitably qualified personnel shall be engaged to supervise foundation work and report any relevant deviations from the assumed soil conditions or intended foundations characteristics.

Design reviews shall be carried out as required and all relevant control processes (including as-building) revised or updated, documented and distributed accordingly.

### 5.4 Geotechnical Strength Factors

The geotechnical strength factor shall be determined in accordance with *Transmission Line Geotechnical Investigation Design Standard*<sup>3</sup> and *Transmission Line Foundation Testing Design Standard*<sup>4</sup>.

## 6. Materials and Durability

### 6.1 Property of materials

#### 6.1.1 Steels

Steel shall be in accordance with one or a combination of the following standards:

---

<sup>2</sup> See Western Power internal document

<sup>3</sup> See Western Power internal document

<sup>4</sup> See Western Power internal document

1. AS/NZS 3679.1 Structural steel part 1: Hot-rolled bars and sections
2. AS/ NZS 3678 Structural steel—hot-rolled plates, floorplates and slabs
3. AS/NZS 1559 Hot-dip galvanized steel bolts and associated nuts and washers for tower construction
4. AS 4291.1 Part 1: Bolts, screws and studs - Mechanical properties of fasteners made of carbon steel and alloy steel
5. AS/NZS 1252.1: High Strength steel bolts with associated nuts and washers for structural engineering. Part 1: Technical requirements
6. AS/NZS 1252.2: High Strength steel bolts with associated nuts and washers for structural engineering. Part 2: Verification testing for bolt assemblies
7. AS 4671 Steel reinforcing material

### 6.1.2 Concrete

Reinforced concrete material shall be as per AS 3600. The surface finish shall be in accordance with AS 3610. Supply of concrete shall be in accordance with AS 1379.

### 6.1.3 Timbers

Reference shall be made to *Full Length Preservative Treated Timber Poles*<sup>5</sup> for types of timber and material properties.

Reference shall be made to AS 1720.2, AS 2082, AS 2878 and AS 3818.11 for requirements of visual and strength graded round timber utility poles. Glued laminated structural timber shall be in accordance with AS/NZS 1328.1.

## 6.2 Durability requirements

### 6.2.1 Steels

All materials shall either be hot dipped galvanized as per AS/NZS 4680 or coated to meet the durability requirements.

The inside surface of hollow sections shall also be protected against corrosion by coating, galvanising or concealment. Reference shall be made to AS 2159, AS 2312 for members below ground or within exposure class C region and for design durability in excess of 50 years.

### 6.2.2 Concrete

The minimum concrete cover as required for the proposed environment shall be consistent with the required design working life plus the anticipated life extension of the supporting structure if any.

Reinforced concrete properties and durability requirements shall be as per AS 3600, AS 2159 and AS 2312. Areas with known high acidity or sulphate content in the soil or ground water shall be allowed for in the cover design.

---

<sup>5</sup> See Western Power internal document

Concrete poles located within 5 km of the coast shall meet the additional durability requirements in accordance with AS 3600.

### 6.2.3 Timbers

All timber components shall meet the requirements of AS 1604.1 "Specification for preservative treatment - Sawn and round timber" for all components falling within the scope of the standard.

### 6.2.4 Sections buried in Ground

Any structural elements buried in the ground shall satisfy the durability requirements of AS 2159. As a minimum, any protective coating shall be 500mm below and above ground.

The following conditions can be taken as aggressive and "additional protection" measures shall be employed and specified when:

1. The maximum corrosion rate is greater than 0.1 mm/year for unprotected steel
2. Soil resistivity is greater than 2000 ohm-cm
3. pH of the soil or ground water is less than 5.0
4. Total sulphates in the soil is greater than 1% or in the water greater than 2500 ppm
5. Chlorides in the water greater than 2000 ppm.

In all other cases, the "nominal" durability requirements shall be satisfactory. The wet soil condition shall be allowed for when designing for corrosion and specifying nominal coating.

## 7. Tower Foundations

### 7.1 Tower Foundations Classifications

The following classifications of tower foundations apply:

Type "A", "AS" Bored pile undercut, straight in dry soil

This is a bored undercut, straight foundation suitable for dry sandy - clay - gravel with layers of cemented soil, and up to and including high strength rock, and rock boulders.

The uplift capacity shall be determined from the lesser of:

1. the weight of material contained within a conical frustum with an angle of 30° (or value recommended in the geotechnical investigation report) to the vertical starting from the correctly profiled extremity of the undercut; and
2. the shear failure model or the equivalent cylindrical model defined by the extremity of the undercut and the depth of the undercut

When this type of foundation is used in a collapsible top soil location, a liner shall be used. Refer to Figure 1 for the typical Type A foundation.

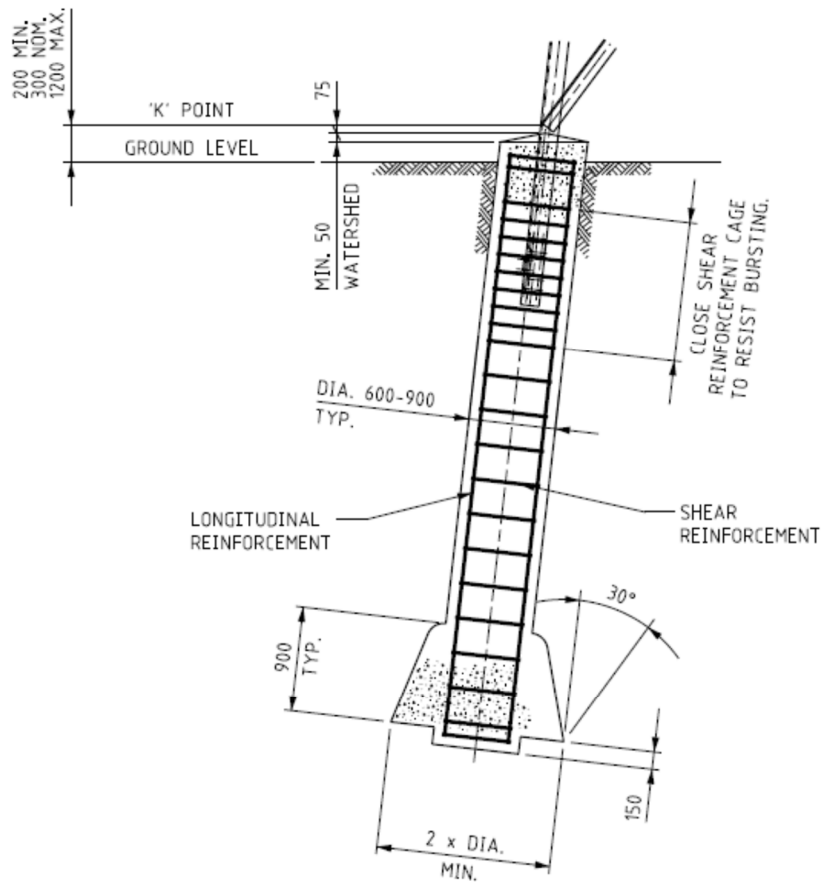

FOUNDATION TYPE A & D

Figure 1: Bored Foundation (Type A & D)

Type "B" Bored pile in dry or wet soil socketed into high strength rock

This is a bored rock socketed foundation suitable for use through sandy-clay-gravel and into competent high strength rock stratum (UCS 20-60 MPa). The rock strength shall be based on uniaxial compressive strength (UCS) as per Table 19 of AS1726. In the absence of UCS testing, other methods may be used to assess strength. These being:

- field guides to assessing the UCS: a medium strength rock is readily scored with a knife and a piece of 50mm diameter core 50 mm long can be broken by hand with difficulty; and harder rock (high strength) cannot be broken by hand but can be broken with a single firm hammer blow
- point load index testing which is another strength test that can be completed on smaller samples. For high strength rock, the point load index is 1 – 3 Mpa

Undercut in dense rock may not be possible. Slot or groove cuts within the socketed layer are optional.

A minimum penetration into the very hard strata of 600 mm or 1x shaft diameter (whichever is greater) is required.

The uplift capacity shall be determined from the lesser of:

1. the foundation/soil friction capacity
2. the weight of material contained within a conical frustum having an angle of 30° (or value recommended in the geotechnical investigation report) to the vertical subtended from the base of the excavations

When this type of foundation is used in a collapsible top soil location, a liner shall be used.

Refer to Figure below for the typical Type B foundation.

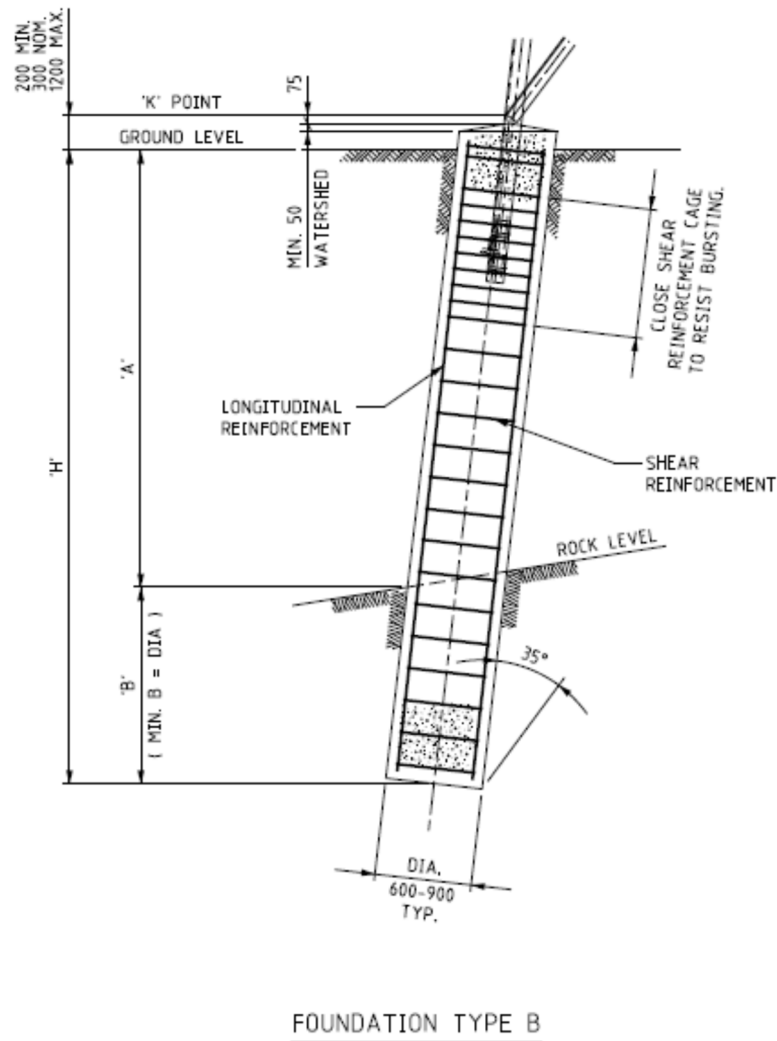
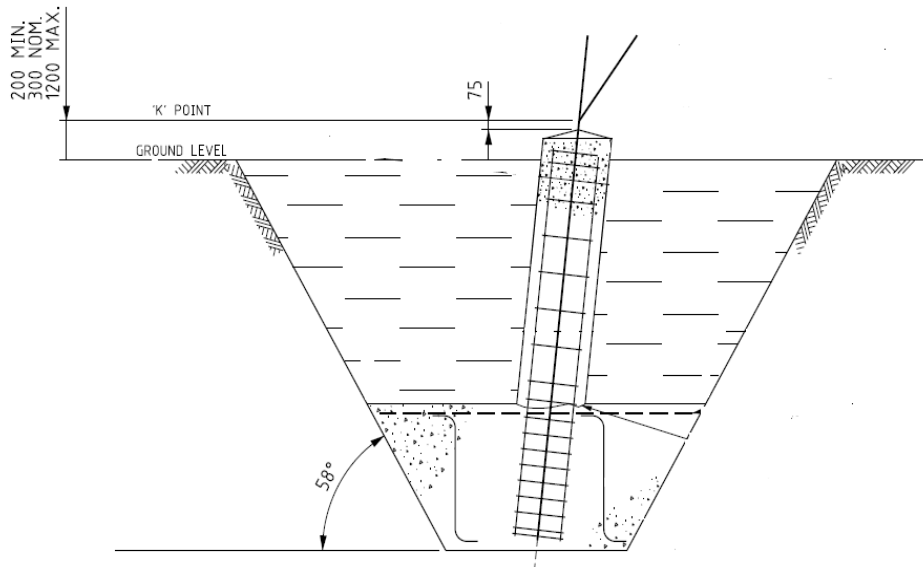

**Figure 2: Minimum requirements for Bored Foundation (Type B)**

Type "C1" Mass concrete / Buried / Capping slab without undercut in dry soil

This is a mass concrete foundation suitable for dry sandy-clay-gravel that is unsuitable for boring because of collapsing soils. The undercut cannot be achieved because of the unstable nature of the soil. The mass slab can be close to ground level for short stub, direct bearing or bolted stub bases with shear keys.

The uplift capacity shall be calculated from the weight of material contained within a 30° conical frustum starting from the top of the base slab. Refer to Figure below for the typical Type C1 foundation.



**Figure 3: Mass Concrete Foundation Type C1 and E1**

Type “D”, “DS” Bored undercut, straight in wet soil

As for type “A” but likely subjected to buoyancy during the life of the line.

The uplift capacity shall be calculated as for a type “A”, “AS” with the water table assumed to be at ground level or as recommended in the geotechnical investigation report.

When this type of foundation is used in collapsible top soil location, a liner shall be used (Type D1). Refer to Figure 1 for the typical Type D foundation.

Type “E1” Mass concrete / buried slab without undercut in wet soil

The uplift capacity shall be calculated as for type “C1” with the water table assumed to be at ground level or as recommended in the geotechnical investigation report. Refer to Figure 3 for the typical Type E1 foundation.

Type “G” Driven pile in dry and wet soil

Driven pile foundations can be used in sandy soil subject to the pile length criteria being met. Pile can be open steel sections, filled or partially filled closed steel sections or precast concrete.

Pile foundations in wet locations shall be designed by assuming the ground water table fluctuation to the ground level or as recommended in the geotechnical investigation report. Refer to Figure 4 for the typical Type G foundation.

The following foundation type classifications are proprietary products:

Type “SA” Soil/mechanical/screw anchor (with or without pressurised grout)

Type “DA” Buried or cast insitu Deadman Anchor in tension only application

Type “RA” Rock Anchor

Type “SP” Screw Pile

Type “MP” Micro Pile

Type "RP" Replacement Pile/Continuous Flight Auger (CFA)

Refer to Western Power's internal drawing for Typical CFA pile outline and soil model.

Type "SG" Steel Grillage

Steel grillage shall be avoided unless the expected line service life is less than 50 years. The minimum steel grillage durability level shall be 50 years.

Other Type/Combinations

Combination of foundation types, capping slabs and tie beams may be used (e.g. bored piles with ring beams, buried slab with soil or rock anchors, pads on bearing piles). The designs of unique combined footings and proprietary products are beyond the scope of this standard.

If unique and complex ground condition is encountered, the Contractor/Consultant shall design special foundations if instructed by Western Power

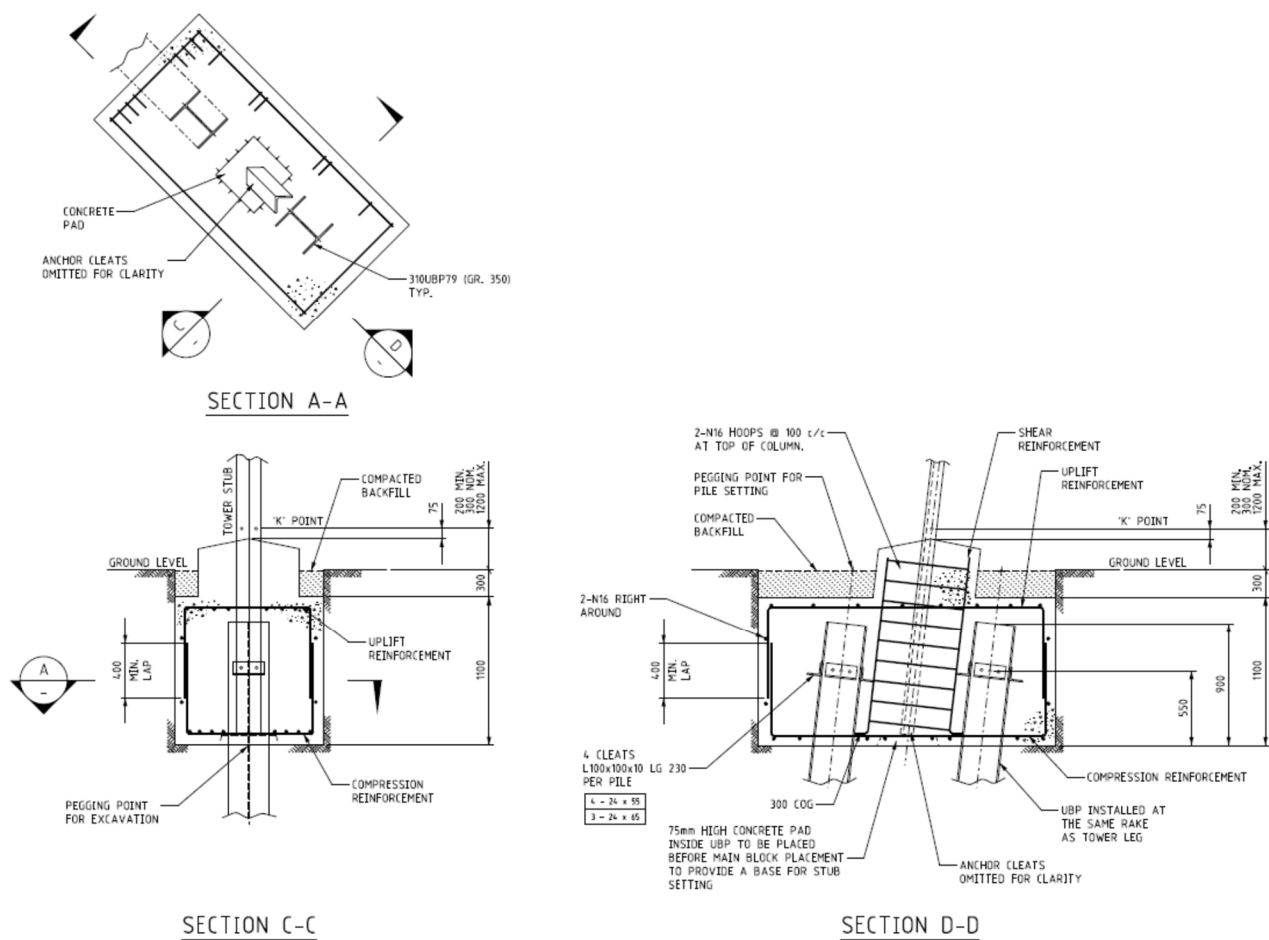

**Figure 4: Typical Type G H-Section Piled Foundation**



## 7.2 Summary of Foundation types

Standard foundation types for Western Power transmission line structures are summarised in Table 7.1.

**Table 7.1: Tower Foundation Types**

Type Designation	Type Description	Relevant Soil Types	Alternate Variations	Reference
<b>1. Bored Foundation</b>				
Type A, AS	Bored undercut - Dry	Dry soil (sandy clay or clayey sand i.e. cemented soil layers).	With liner in dry unstable soil at upper layers.	AS/NZS 7000 L4.4.1
Type B	Bored socketed – Rock Dry/Wet	Dry or wet soil but socketed into moderate to high strength rock.	With liner in dry unstable soil at upper layers.	AS/NZS 7000 L4.4.4
Type D, DS	Bored undercut - Wet	Dry soil as above during construction but may be subjected to buoyant conditions.	With liner in dry unstable soil at upper layers.	AS/NZS 7000 L4.4.1
<b>2. Mass Concrete Foundation</b>				
Type C1	Mass without undercut - Dry	Same as above but where undercut is not possible because of unstable soil at founding depth.	Type A or B with liner	AS/NZS 7000 L4.5
Type E1	Mass without undercut – Wet	Water encountered above founding level where undercut is not possible.	Type D with liner.	AS/NZS 7000 L4.5
<b>3. Other Foundation</b>				
Type G	Driven Steel Pile	Dry or wet sandy soil where pile length criteria can be achieved.	Any suitable type stated above.	AS/NZS 7000 L4.6.2 and AS 2159.
Type SA, DA, RA, SP, MP, RP	Proprietary Products: Soil Anchor, Deadman Anchor, Rock Anchor, Screw Pile, Micro Pile, Replacement Pile.	All range.	Any combination with foundation stated above.	AS/NZS 7000 L4.6, AS 2159, Eurocode 4, AASHTO LRFD Bridge Design Specifications and proprietary specifications.
Type SG	Steel Grillage with design life less than 50 years.	Dry or wet soil (sandy clay or clayey sand i.e. cemented soil layers).	Concrete encased grillages.	ASCE 10-15, AS 3600.

## 7.3 Geotechnical Design of Bored Foundations

### 7.3.1 Bored Undercut Foundation Uplift Capacity

The uplift capacity of bored undercut foundations shall be designed as per the requirements stated in Table 7.2.

**Table 7.2: Bored Undercut Uplift Capacity (Type A, AS and Type D. DS)**

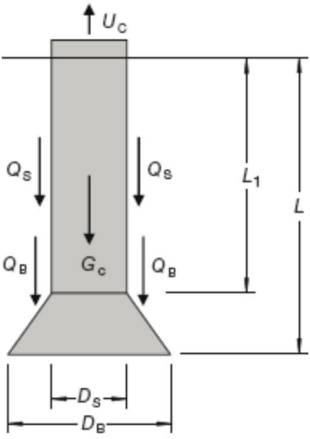
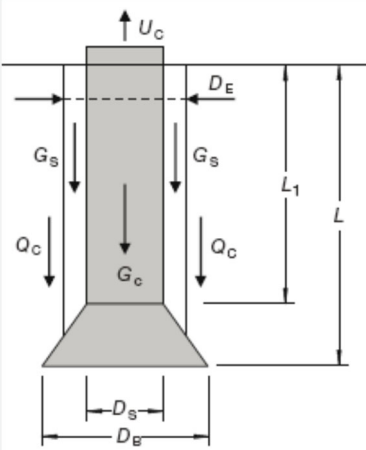
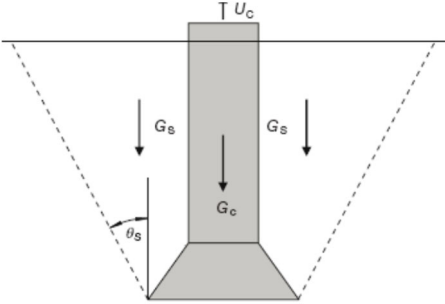
Failure Model	AS/NZS 7000 Reference	Specific Requirements <sup>6</sup>
<p>Shear Failure Model</p> 	L4.4.2.2	<p>Shaft Adhesion factor, <math>\alpha</math> shall be taken from figure L7 of AS/NZS 7000.</p> <p>Coefficient for horizontal stress (K) shall be assessed from table L4 of AS/NZS 7000.</p>
<p>Cylindrical Failure Model</p> 	L4.4.2.3	Bell diameter reduction coefficient, $\zeta$ shall be 1.5.
<p>Cone Failure Model</p> 	L4.4.2.4	Pullout angle, $\theta_s$ , shall be 30°.

<sup>6</sup> Unless otherwise recommended in the geotechnical investigation report.  
 Uncontrolled document when printed  
 © Copyright 2022 Western Power

### 7.3.2 Bored Undercut Foundation Compression

The compression capacity of bored undercut foundations shall be design as per the requirements stated in Table 7.3.

**Table 7.3: Bored Undercut Compression Capacity (Type A and Type D)**

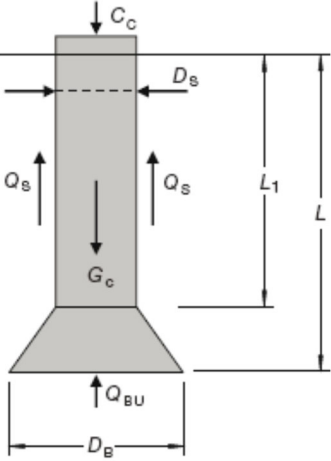
Failure Model	AS/NZS 7000 Reference	Specific Requirements <sup>1</sup>
<p>Compression with end bearing</p> 	L4.4.3	<p><math>\phi_{cc}</math> in equation L32 of AS/NZS 7000 shall be 1.2.</p> <p>No reduction in side resistance (<math>Q_s</math>) shall be considered for mobilising full bearing at the base of undercut (<math>Q_{BU}</math>).</p>

### 7.3.3 Bored Socketed Foundation Uplift Capacity

Two uplift case failure modes (pier and cone pullouts) should be considered for bored socketed into rock as detailed in Table 7.4.

**Table 7.4: Bored Socketed Uplift Capacity (Type B)**

Failure Model	AS/NZS 7000 Reference	Specific Requirements <sup>1</sup>
Mobilisation of rock mass 	L4.4.4.2	Cone angle in rock, $\theta_R$ shall be $30^\circ$ for soft/ heavily weathered rock mass and $35^\circ$ for intermediate quality rock mass.  Cone angle in soil shall be $30^\circ$ .
Shear failure model 	L4.4.4.3	Coefficient for horizontal stress (K) shall be assessed from table L4 of AS/NZS 7000.  Rock-concrete interface shear strength ( $f_{RC}$ ) shall be 500 kPa.

### 7.3.4 Bored Socketed Foundation Compression Capacity

The compression capacity shall be determined as per Table 7.5.

**Table 7.5: Compression Capacity of Bored Socketed Foundation (Type B)**

Failure Model	AS/NZS 7000 Reference	Specific Requirements <sup>1</sup>
Compression with end bearing 	L4.4.4.4	$\phi_{cc}$ in equation L41 of AS/NZS 7000 shall be 1.2.  No reduction in side resistance ( $Q_s$ ) shall be considered for mobilising full bearing at the base of socket ( $Q_B$ ).

### 7.3.5 Effects of Liner on Bored Foundation (Type A, B, D)

A permanent liner shall be used where bored foundations are designed for sandy soil (i.e. susceptible to soil collapse during excavation).

The friction angle between concrete/steel and soil ( $\delta$ ) shall be reduced considering the interface materials (clause 6.3.1.1 of IEEE 691).

The reduction factor shall be taken from Table 7.6 unless proven otherwise during foundation testing.

**Table 7.6: Soil friction angle reduction factor**

Interface materials	Reduction factor
Sand/ rough concrete	1.0
Sand/ smooth concrete	0.8
Sand/ rough steel	0.7
Sand/ smooth steel	0.5

## 7.4 Geotechnical Design of Mass Concrete Foundation

### 7.4.1 Mass concrete undercut Uplift Capacity

This foundation type shall not be used.

### 7.4.2 Mass concrete undercut Compression Capacity

This foundation type shall not be used.

### 7.4.3 Mass Concrete without Undercut uplift capacity

Uplift capacity of a mass concrete foundation without undercut shall be determined as per Table 7.7.

**Table 7.7: Uplift Capacity Mass Concrete without Undercut (Type C1 and E1)**

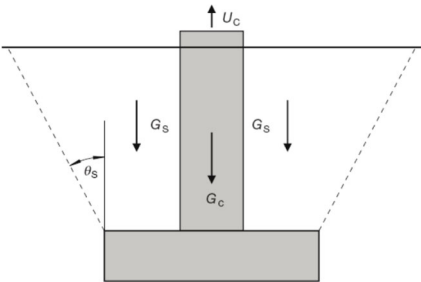
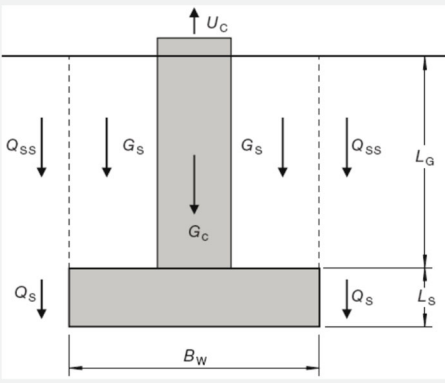
Failure Model	AS/NZS 7000 Reference	Specific Requirements <sup>1</sup>
<p>Cone pullout model</p> 	L4.5.2	<p>Pullout angle, <math>\theta_s</math> shall be <math>30^\circ</math> with the following three uplift design models-</p> <ol style="list-style-type: none"> <li>Soil frustum above the pad and <math>Q_s</math> along the side of the pad.</li> <li>Soil frustum from the middle of the pad and <math>Q_s</math> along the side of the remaining half-pad</li> <li>Soil frustum from the toe of the pad and no <math>Q_s</math>.</li> </ol>
<p>Cylindrical failure model</p> 	L4.5.4	<p>Shaft Adhesion factor, <math>\alpha</math> shall be taken from figure L7 of AS/NZS 7000.</p> <p>Coefficient for horizontal stress (K) shall be assessed from table L4 of AS/NZS 7000.</p> <p>The following three uplift design models-</p> <ol style="list-style-type: none"> <li>Soil frustum above the pad and <math>Q_s</math> along the side of the pad.</li> <li>Soil frustum from the middle of the pad and <math>Q_s</math> along the side of the remaining half-pad</li> <li>Soil frustum from the toe of the pad and no <math>Q_s</math>.</li> </ol>

### 7.4.4 Mass Concrete without Undercut Compression Capacity

The design methodology for these types of foundations (Type C1 and E1) is similar to the bored foundations, with modification for their geometry as appropriate and the failure occurring in disturbed backfill material.

The failure model shall be similar to Table 7.3 for normal soil and Table 7.5 for rock mass. Side resistance ( $Q_s$ ) shall be ignored. The design of mass concrete foundation without undercut (type C1 and E1) shall be similar to 7.4.2 (compression capacity of mass concrete foundation with undercut).

#### 7.4.5 Mass Concrete under Bending and Compression

The ultimate bearing stress at the extreme fibre shall not exceed the bearing capacity calculated using the Terzaghi equation and the eccentricity of load should be within a distance equal to one sixth width from the pad centre.

#### 7.5 Geotechnical of Piled Foundation

Piled foundations (Type G) shall comply with clause L4.6.2 of AS/NZS 7000 and AS 2159 unless otherwise modified by this standard.

Pile caps shall not be considered as contributing to lateral load resistance unless they have been cast against undisturbed ground or compacted engineering fill. The top 300 mm of soil shall be ignored in calculations for lateral resistance.

Pile groups shall be checked with the reduced group efficiency by considering the block failure model.

#### 7.6 Steel Grillages

Steel grillage foundation with galvanisation layer only shall not be used for supports with expected working life in excess of 50 years. Refurbishment cost of steel grillage versus concrete footing shall be considered. Design of grillage foundation shall be in accordance with ASCE 10-15.

#### 7.7 Soil Lateral Capacity

Soil lateral capacity shall be evaluated in accordance with Appendix L3 of AS/NZS 7000, based on Rankine's, Coulomb's or similar theories or determined using numerical analysis based on the geotechnical investigation report.

#### 7.8 Design for combined load

Combined loads on foundations shall satisfy the following equation:

$$\left( \frac{S}{\phi_g R_n} \right)_{Vertical} + \left( \frac{S}{\phi_g R_n} \right)_{Lateral} \leq 1.0$$

#### 7.9 Stability of Slopes

Foundations on slopes greater than 15° shall be evaluated for slip failures. Refer Section 7.11 for serviceability requirements.

## 7.10 Structural Design of foundation Elements

### 7.10.1 Design of Studs and Cleats

Stub and cleat shall be designed as per ASCE 10-15 (with strength factor 0.9) and the following additional requirements:

**Table 7.8: Stub-Cleat additional design requirements**

Failure mode	Reference standard
Connection shear stress	Clause 9.3.2.1 of AS 4100
Connection bearing stress	Clause 9.3.2.4 of AS 4100
Stress on bolts for combined effect of shear and moment, or shear and tension	ASCE 10-15 Clause 9.3.2.3 of AS 4100.

### 7.10.2 Bored Columns or Chimneys of Mass Concrete

#### Design Actions:

Forces on the foundation shall be for a combination of the following two actions:

1. The load applied at the tower K-point
2. The distributed pressures from the soil (passive soil pressure due to lateral reaction).

The designer shall assess whether any localised forces exist which may require additional strength in the foundation.

A minimum stub to column eccentricity of 50 mm (or higher if required for constructability) shall be allowed for in the design.

#### Construction Joints:

Construction joints shall be above the neck level.

#### Reinforcing Steels:

Bored columns or chimneys shall be designed for the combined axial and bending actions. Steel curtailments shall be in accordance with AS 3600. A minimum construction tolerance of 25mm shall be provided.

Bonded reinforcing bars may be used as part of the earthing system subject to the following conditions:

- Electrical designers and civil designers to coordinate the design of the embedded earthing to prevent concrete spalling and corrosion
- Reinforcement to be welded and bonded to provide electrical continuity
- Sufficient concrete cover over the steel reinforcement to minimise corrosion
- Thermal ratings of earthing conductors and joints (excluding contribution from the embedded earthing) are not to be exceeded

#### Containment Steels:

Where localised compressive stresses are generated near concrete surface, the bursting effect shall be considered.



Assessment for containment steel is required in accordance with AS 3600 where the load from the main steel member is not the full depth of the foundation column.

An extended zone of transverse steel shall be considered to allow for construction tolerances. Additional hoops shall be added to the entry of the stub.

Containment steel is not required for uplift loading where a stub has cleats in an under ream (belled) near the lower level of the foundation.

#### Unreinforced Upstands:

Crack control chemical admixture or fibre shall be added to exposed and unreinforced concrete upstands requiring a class 2 or better surface finish in accordance with AS 3610.

### **7.10.3 Extensions**

#### Concrete Columns / Upstands

A foundation column extension shall be designed where sloping ground is encountered and the level differential is less than 1m and cannot therefore be accommodated with a combination of support leg extension.

#### Outriggers / Anchor Blocks

Horizontally extended foundation features shall be designed as integral part of the footing. The extension features shall not encroach into adjacent rights of way and may be jointed to a combination of foundation systems (e.g. ground anchors or driven piles). The effectiveness of closely spaced foundation system shall be evaluated.

Replacement cost of low durability (<50 years) ground anchors and buried ties if any shall be considered.

When the extension is added to an existing foundation, the durability of reinforcing steels across joints and potential drill damage to existing reinforcing bars if any shall be considered.

### **7.10.4 Slabs and Beams**

Mass concrete foundations slabs and beams shall be designed in accordance with AS 3600 as either reinforced or unreinforced concrete. The components shall be capable of withstanding the total bending moments generated by compression or uplift combined with lateral actions.

Design for combined bending and shear in plain concrete shall in accordance with Section 15 of AS 3600.

Cast insitu flexible thin slabs or beams less than 300 mm thick shall be avoided. Precast slabs and beams shall be capable of transferring bearing loads evenly across the width of the slab. Punching shears shall be checked.

Minimum crack controls shall be as per clause 9.4 of AS 3600. The finished surface slope of slab shall be inclined to drain water away from the footing. A minimum 300 mm regress layer shall be allowed for as required.

For undercut foundations the toe of the footing shall be designed for the additional load and bearing pressures developed on the undercut (Figure 5).

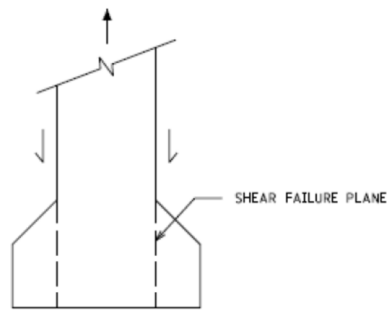

**Figure 5: Localised shear failure at undercut (for uplift)**

### 7.10.5 Pile Caps

Pile caps shall be designed in accordance with AS 3600. Specific requirements stipulated in clause 12 of AS 3600 shall be adhered to.

The design shall take into account the assumed eccentricity of pile location(s) and construction tolerances.

Additional requirements for pile cap design:

1. Pile cap thickness shall be sufficient to encase the specified embedment length of the structure anchorage system.
2. Embedded structure steelwork shall not protrude past lower reinforcement levels.
3. Load bearing cleats shall be located within and between top and bottom layers of reinforcing steel.

### 7.10.6 Driven Piles

Pile elements shall be designed in accordance with AS 2159, or selected according to product specifications complying with relevant Australia Standards.

Axial, eccentric and lateral actions shall be taken into account. Timber piles shall not be used.

## 7.11 Design For Serviceability

### 7.11.1 Foundation Movements

Tower foundation translational, rotational movements and settlements shall be evaluated in areas with soil instability, expansive/compressible or very soft and liquefiable soil layers. Such movements shall be limited to maintain a serviceable state of the tower without jeopardising the rated ultimate capacity of the tower.

Monitoring of foundation movements at high risk areas shall be considered as one of the design solutions. Reference may be made to *AASHTO LRFD BRIDGE DESIGN SPECIFICATION* for assessment of shallow pad elastic settlement based on SPT (N) values.

### 7.11.2 Differential Settlements

The structure and foundation shall be checked for loadings due to measured or anticipated differential settlements, if any. The following shall also be avoided:

- non-uniform fill or locations with non-uniform parent soil layer density beneath footings
- inconsistent compaction efforts between adjacent tower footings.

### 7.11.3 Constructability

The extent of excavation, and machinery operation zone and its operating limits shall be evaluated for the proposed and alternative foundations at each tower location.

Access costs and safety of plant and machinery on sloping ground shall be evaluated.

The combined foundation type or proprietary products with or without additional geotechnical investigations shall be considered at difficult sites to reduce project risk and the expected overall project cost. Geotechnical investigations shall be carried out in accordance with *Transmission Line Geotechnical Investigations Design Standard*<sup>7</sup>. Capabilities of contractors shall be considered when proposing non-conventional foundation types.

## 8. Pole Foundations

### 8.1 General

Pole foundations shall be designed as per clause L3 of AS/NZS 7000:2016 unless otherwise modified by this standard.

### 8.2 Types of Pole Foundations

Pole foundations shall be moment resisting foundations. The following foundation types shall be used for pole structures:

1. Direct buried foundation where the pole body is embedded into the ground.
  - a. buried in soil

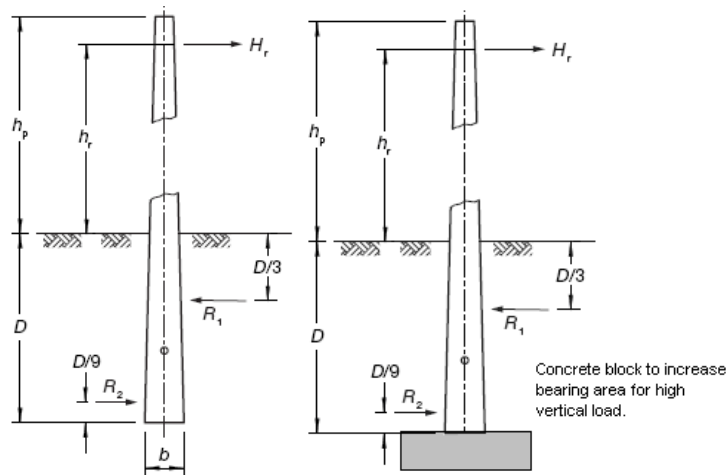
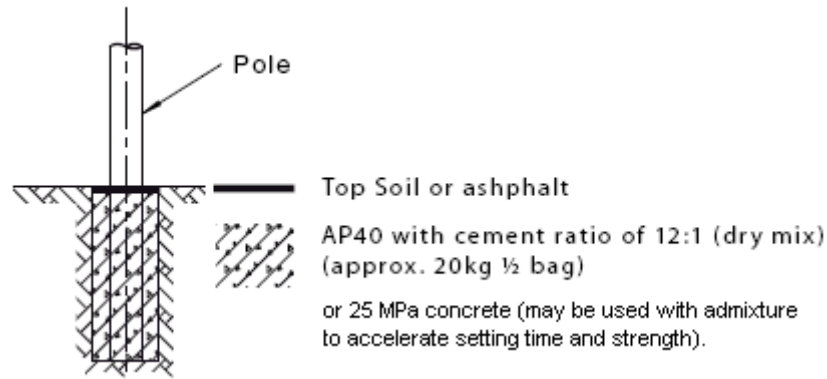

Figure 6: Direct buried pole

- b. buried in soil with hip and toe blocks
- c. buried in concrete encasement / cement stabilised backfill

<sup>7</sup> See Western Power internal document



**Figure 7: Direct buried pole with concrete encasement**

- d. buried in concrete encasement with or without top blocks

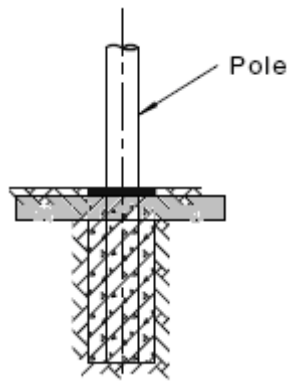

**Figure 8: Direct buried pole with wide top concrete encasement**

- 2. Concrete caisson (bored concrete) foundations where pole is connected to the foundations via anchor base plate and anchor bolts.

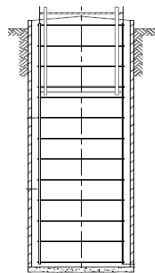

**Figure 9: Typical caisson foundation with base plate and anchor bolts**

- 3. Pad and pedestal foundation
- 4. Soil, rock or deadman anchor or stayed pole
- 5. Proprietary foundation system

## 8.3 Direct Buried Pole Embedment Depth

### 8.3.1 Timber Poles

#### Standard Design

Timber poles embedment based on the legacy “Height/12+1.4m” empirical formula shall be treated as semi-rigid foundation. Application of this formula shall be conditional for transmission line support structures as stated below:

1. Soil conditions:
  - a. Firm/Medium or Stiff/Dense;
  - b. minimum 10 blows over 300 mm with a standard penetration test in sand, 6 blows/300 mm in silt/clay;
  - c. or 6 blows/300mm using a dynamic cone penetrometer;
  - d. or 6 blows/300 mm using a Perth sand penetrometer;
  - e. water level below pole base;
  - f. flat stable terrain.
2. Pole characteristics:
  - a. Timber grade S3 or better in accordance with AS 3818.1;
  - b. pole groundline diameter meets the requirements of *Full Length Preservative Treated Timber Poles*<sup>8</sup>;
  - c. 21.5 m maximum length.
3. Loads on pole:
  - a. 20 kN maximum ultimate tip load (10kN working load) applied at 300 mm below tip;
  - b. 2.5 kN maximum vertical phase load under everyday wind condition;
  - c. 50 kPa maximum base bearing pressure.
4. Line importance:
  - a. Level II or lower;
  - b. up to 50 years design working life.

#### Site Specific Design

Standard timber pole foundation embedment depth and soil treatment is not suitable in wet soil, weak sand or rock layer. Site-specific design shall be carried out at locations where the site conditions do not meet the requirements above. All timber pole foundation shall be design as non-rigid footing. The embedment depth shall be determined using the Brinch - Hansen method as described in clause L3.3 of AS/NZS 7000:2016 with the following modifications:

1. The soil parameters shall be as below:

---

<sup>8</sup> See Western Power internal document

**Table 8.1 Soil parameters for timber pole foundation**

Soil Type	Unit Weight (kN/m <sup>3</sup> )		Soil shear strength Cu (kPa) *	Angle of Friction *
	Dry	Wet		
Cohesive Soils	Table L1 AS/NZS 7000			
Loose, coarse to fine sand	18	9	2	30°
Medium dense, coarse to fine sand	20	10	2	35°
Dense to very dense, coarse to fine sand	22	12	2	40°
All rock including weathered	22	12	2	40°

\*The adjustment to the Brinch Hanson calculator was based on Western Power tests on non-rigid timber pole foundation in sandy soil.

The soil type shall be confirm using a Dynamic Cone Penetrometer (DCP) or Perth Sand Penetrometer (PSP) unless loose sand was assumed.

2. The component strength factor for non-rigid pole foundation shall be as below:

**Table 8.2 Component strength factor**

Limit state	Component strength factor
Ultimate	1
Serviceability	0.7

3. The effective footing diameter shall be adjusted in accordance with Table 8.3
4. The water table shall be in accordance with Table 8.4

### 8.3.2 Other Poles

All other poles embedment depth shall be determined using the Brinch - Hansen method as described in clause L3.3 of AS/NZS 7000:2016. The bearing capacity shall be evaluated in accordance with clause L4 of AS/NZS 7000:2016.

### Effective Diameter

The effective footing diameter shall be determined based on type and quality of backfill in accordance with the following Table:

**Table 8.3: Effective Footing Diameter**

Type of backfill	N, blows per 300mm	Effective Diameter
Cohesionless insitu backfill with or without cement mix.	SPT≤10 DCP≤6 PSP≤6	Average diameter of the buried shaft.
	SPT=30 DCP=12 PSP=8	Thickness of the backfill ring up to one shaft diameter thick + diameter of the shaft.
Imported backfill compacted in 150-300 mm layers using 596 kJ/m <sup>3</sup> effort and tested in accordance with AS 1289.5.1.1 and AS1289.5.8.4.	-	Thickness of the backfill ring up to one shaft diameter thick + diameter of the shaft.
Concrete encasement, pad or caisson with or without liner.	-	Pad width or encasement diameter.

Effects of flexible toe block if any shall be evaluated. Unreinforced concrete encasement shall be checked for shear and thermal expansion.

### 8.3.3 Water Table

The design high water table shall be as below:

**Table 8.4: Water table based on design return period**

Pole	Wind Design Return Period (years)*	Water Level
Non wood pole	200	Based on historical seasonal maximum typically a 100 year ARI flood or as assessed by field investigation. For structures within a flood plain i.e. river bank, a 1 in 100 years hydrology modelling to be carried out.
	≤100	
Wood pole	100	Based on historical seasonal maximum or field inspection record.
	50*	

\*The high wind period within SWIN is usually between October to March, the dry summer period (refer Fisheries Research Report [Western Australia] No. 266, 2015 and Bureau of Meteorology climate data).

### 8.3.4 Sloping Ground

Unless otherwise determined using the established soil formula or numerical analysis, pole embedment depth shall be increased on sloping ground as follows:

1. For a continuous slope,  $\theta$  of  $30^\circ$ , the effective embedment depth,  $D_e$  of a direct buried uniform shaft shall be  $1/2$  of the buried depth,  $D$  (refer Figure 10). The value shall be linearly interpolated for slope less than  $30^\circ$ .
2. The effective embedment depth,  $D_e$  may be increased to  $2/3$  of the buried depth if the downhill end is effectively retained or when the critical impact load is perpendicular to the slope or when a rigid foundation is put in place. Retaining wall displacing more than  $L/150$  over its service life shall be treated as ineffective ground retention. Effects of overburden, construction vehicle and slope stability shall be investigated.

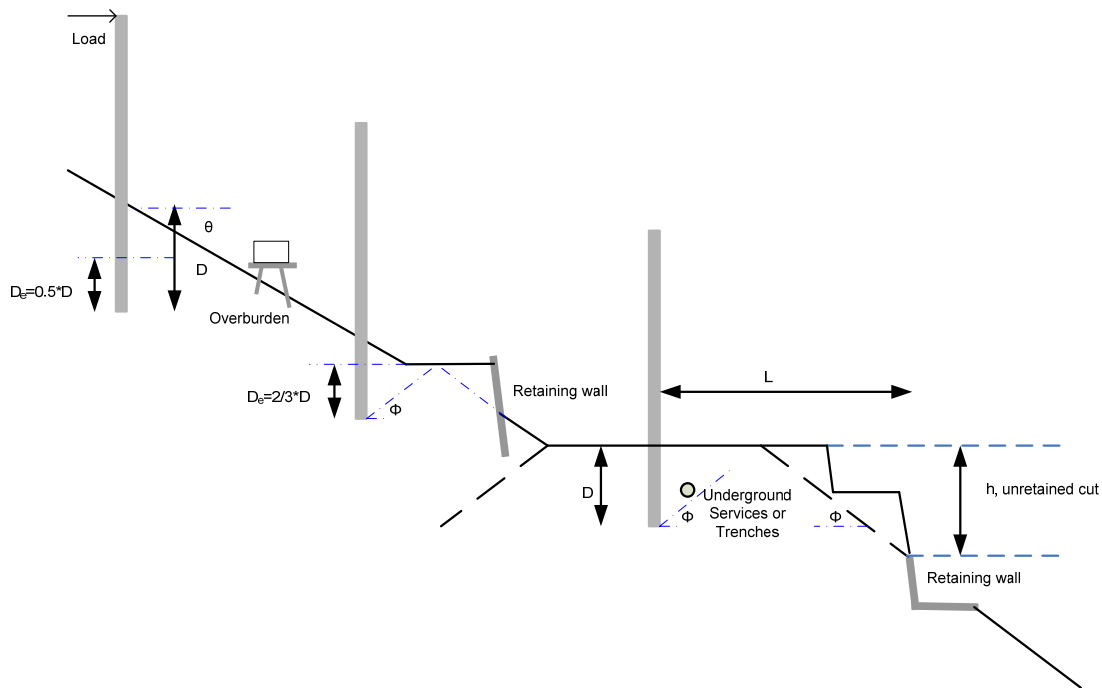

**Figure 10: Poles on Sloping Ground**

3. The embedment depth for a support at a valley (not a waterway) shall be determined assuming a flat ground.
4. Any surface soil layer susceptible to erosion or cracking shall be considered as top soil. A minimum top soil layer of 200 mm shall be assumed for uncompacted fill.
5. Specific embedment depth calculations shall be carried out for all other non-uniform foundation type (e.g. pad and pedestal), where the uphill slope is non uniform and when the ground slope is greater than  $30^\circ$ .
6. A geotechnical investigation shall be carried out for sloping ground,  $\theta$  greater than  $15^\circ$  and/or for unretained overburden load (e.g. from storage tanks, fills, machinery, stockpile, heavy equipment etc) or if unstable debris/waterway/slip line of action crosses the foundation. Site stabilisation work if any shall be put in place before installing or augmenting the support structure.



## 8.4 Excavation and Underground Services

1. Excavation near the edge of the pole foundation (refer Figure 10) shall satisfy the following equation:

$$L \geq \frac{D+h}{\tan\phi}$$

L = Horizontal distance between edge of footing and edge of unretained cut, (m).

D = Buried depth of footing, (m).

h = Vertical distance of unsupported excavation between support ground line and stable slope, (m).

$\Phi$  = Effective soil internal angle of friction, (degree).

2. Temporary pole supports or braces shall be put in place if the excavations encroached into the stable slope. Permanent cut into the stable slope shall be effectively retained. Disturbed soil shall be removed and replaced with suitable compacted backfill.
3. All buried services, trenches and the like within a radius equal to the embedment depth from the pole center line shall be capable of sustaining the resultant ultimate pressure without permanent deformation. A reduction in pole foundation capacity shall be evaluated if the dependable backfill is or can potentially be removed and not reinstated to the required specification during installation or refurbishment of adjacent buried services, trenches and the like including street features such as lights, signboards, bus stops, trees, fences etc.

## 8.5 Design of Foundation Elements

### 8.5.1 Design of Concrete Footings

Design of concrete footing shall be in accordance with Section 7.10.

### 8.5.2 Design of Ground Stay Anchors

The stay anchor shall be designed as per Clause L5 of AS/NZS 7000:2010 with a maximum soil strength factor of 0.6. The anchor assembly shall be capable of resisting the imposed ultimate loads. Reduction in ground anchor rating shall be considered for closely spaced anchors according to manufacturer specifications. The maximum number of stays attached to a single anchor shall be 2 provided the angle between the two is less than 15 degrees in the vertical plan and both are attached to the same shaft.

The typical soil condition shall be assumed to be soft to dense, dry or wet coarse sand layer in coastal or inland of the SWIN region. Refer Appendix L of AS/NZS 7000.

Selection of anchoring system shall consider ground movement under sustained loads or creep, ease of installation, lifetime cost and durability. Ground stay anchors shall have a separate foundation to the pole shaft.

The ground anchors will move to develop the full passive pressure wedge. If the amount of post installation creep has not been specifically determined, a minimum value of 200 mm shall be assumed.

### 8.5.3 Design of Steel Elements

#### Steel Shafts:

The embedded section shall be designed to resist the overturning moment, shear and axial loads in accordance with ASCE/SEI 48-11 and Appendix K of AS/NZS 7000:2016. Refer to *Transmission Line Loadings and Support Structure Design Standard*<sup>9</sup> for further information.

#### Anchor Bolts:

Anchor bolts shall be designed either as per ASCE/SEI 48-11 or AS 3600 and AS 4100 with additional requirements stated below:

A maximum strength factor of 0.8 shall be considered for design in accordance with AS 3600 and AS 4100.

The design shall be checked to ensure that the bolts clear the reinforcement in the pedestal or plinth or base. A minimum construction tolerance of 50 mm shall be provided for supervised construction work. This value may be increased to the greater of 75 mm or 3 times the bolt diameter for ease of construction. The bolt length shall be checked to ensure that the bottom of the bolt has adequate concrete cover and the top end protrusion is not more than 1.5 diameter above the locking nut.

Anchor bolt and pedestal reinforcement design shall be checked to ensure that there is adequate development length for each bar to transfer the load from the structure or equipment to the concrete. Bars (bolts) mechanically anchored in concrete with an end plate shall conform to Clause 13.1.4 AS 3600.

Only un-grouted base plates shall be used. Bolts in un-grouted base plates (refer to Figure 11) shall be designed for bending stresses when the clear distance below the levelling nut is greater than one and a half bolt diameter. The greater of bolt length,  $c$  plus unsupported bolt embedment length or 100 mm shall be considered bending in reverse curvature. Unprotected anchor bolts shall be sized to account for the effects of corrosion.

Locking nuts shall be provided. Anti-theft nuts shall be considered. The locking mechanism shall not damage the thread. Mild steel washers shall be installed between the two nuts when a pole preset is applied by adjusting the nuts. These requirements may be waived if a double nut fixture is provided or calculations showed that the concentrated load will not collapse the threads. The washers thickness if any shall be at least 1.2 times the preset gap.

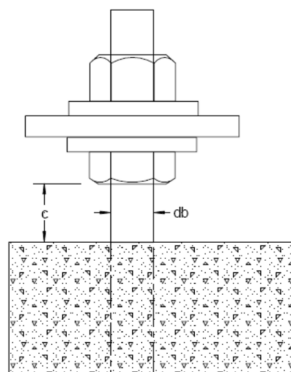

**Figure 11: Anchor bolt with un-grouted baseplate (locking devices not shown)**

#### Anchor Plates and Baseplates:

<sup>9</sup> See Western Power internal document

The thicknesses of anchor plates, baseplates and stiffeners shall be determined by keeping the combined stress on the plates to within the maximum yield strength of the plate materials as per ASCE/SEI 48-11 or AS 3600, AS 3678 and AS 4100.

A maximum strength factor of 0.9 shall be used (table 3.4 of AS 4100:1998) for anchor plate design. When there is a potential for anchor plate to deform, the effective concrete bearing area shall be calculated.

Drain hole(s) shall be provided for all caisson foundation with unconcealed shaft.

Bearing Plates:

The design of the bearing plate shall consider construction, permanent or temporary equipment and fixture loads and shall be in accordance with either ASCE/SEI 48-11 or AS 4100.

## 8.6 Design for Serviceability

### 8.6.1 Foundation Rotations

The foundation angular rotation shall be checked to maintain the maximum allowable pole deflection. Unless otherwise determined using numerical analysis or field testing, the following direct buried foundation rotation on a flat terrain can be expected after a critical (serviceability) weather event and shall be allowed for as a minimum:

**Table 8.5: Flexible or Semi-rigid Timber Pole Foundation Rotation**

Timber Pole <sup>1</sup>	Soil Condition <sup>2</sup>		
	Soft/Loose	Firm/Medium	Stiff/Dense
Fixity point below ground (% buried depth)	1/2 to 2/3	1/3 to 1/2	1/3
Non-elastic deflection (Degree of foundation rotation)	2°	1°	0.5°

<sup>1</sup> Timber poles meeting Section 8.3.1 and 8.3.2 requirements.

<sup>2</sup> Soil properties as defined in Table L1 and L2 of AS/NZS 7000 for cohesive and non-cohesive soils.

**Table 8.6: Rigid Pole Foundation Rotation**

Pole	Soil Condition		
	Soft/Loose	Firm/Medium	Stiff/Dense
Fixity point below ground (% buried depth)	1/2	1/3	200 mm <sup>(3)</sup>
Non-elastic deflection (Degree of foundation rotation)	1°	0.5°	0.25-0.5°

<sup>3</sup> For steel/concrete poles in dense soil, the point of foundation rotation shall be taken as 200 mm below ground level. This shall also apply to all caisson or equivalent buried pad rigid foundation, irrespective of soil conditions.

The buried depth for fixity point calculation shall be the lesser of the embedment depth or 10 times the effective diameter measured from either the stable flat ground level or average ground level in case of an inclined ground surface.

Impacts of toe blocks, partial encasement/plugs and stays shall be evaluated by considering the resulting bending loads. Lateral stiffness of toe blocks, creep in stays (including ground anchor) and slope stability shall be assessed.

### 8.6.2 Preset

Preset of pole if any shall be allowed for when detailing the steel reinforcement and anchor bars. Adequate concrete cover shall be maintained and the allowable construction tolerances specified. Refer to *Transmission Line Loadings and Support Design Standard*<sup>10</sup> for pole preset requirements.

<sup>10</sup> See Western Power internal document

### 8.6.3 Settlements

Settlement of pole foundation is not required to be assessed under the following circumstances:

1. Base bearing stress is less than 200 KPa under service load; or
2. Clearance tolerance is greater than 500 mm; and
3. Underlying soil contain no peat, organic, liquefiable, compressible, soft/loose and very soft/loose layers.

Reference may be made to *AASHTO LRFD BRIDGE DESIGN SPECIFICATION* for assessment of shallow pad elastic settlement based on SPT (N) values. Settlements shall be limited to 25 mm.

Numerical analysis and foundation tests are both acceptable form of verification methods.

### 8.6.4 Constructability

Constraints such as plants access, outages, hydrostatic pressure, concrete buoyancy, traffic controls, logistics, capabilities and experience of construction crews and safety during construction shall be considered in design.

When selecting and designing pole foundation within congested space and high risk area, in particularly under or near live wires, close to urban establishments, near places of assembly, along roads, adjacent to underground services, on steep sloping ground or next to a vertical drop, a detailed risk assessment shall be conducted.

## 9. Backfill and Concrete Encasement

The following is a list of suitable backfill and concrete composition for transmission support structures:

**Table 9.1: Backfill and Concrete Encasement**

Application	Supply standard or specification	Composition	Testing Standard and Workmanship Quality Control
Foundation relying on strength of backfill or encasement and foundation relying on weight of backfill/concrete	AS 2758.1, AS 3972	<p><u>Dry Mix A</u></p> <ul style="list-style-type: none"> <li>- 50% by volume 14, 20, 28 or 40 mm nominal size graded coarse <u>angular</u> aggregate, and</li> <li>- 50% by volume <u>crushed</u> fine aggregate, plus</li> </ul> <p><u>Dry Mix B</u></p> <ul style="list-style-type: none"> <li>- 100% by volume <u>crushed</u> fine aggregate, plus</li> </ul>	AS 1289, nuclear density gauge and calibrating test or manual pressure dial records (for pole) and producer statement – construction.
	Main Road Specification 501	Gravel, crushed rock or hydrated cement treated crushed rock base basecourse.	Main Road Annexure 501A
	AS 1379	25, 32, 40, 50 or 65 MPa reinforced or plain concrete with or without fast cure, sulphate/chlorides resistance and low water ratio attributes.	AS 1012
	-	Cement stabilised (1:6-8 dry mix ratio) insitu clean sand without peat, blue clay, organics and top soil (with less than 12% fines) or equal premix backfill.	AS 1289, penetration count records and/or nuclear density gauge and calibrating test records or manual pressure dial records (for pole) and producer statement – construction.
	AS 3648	Generic dry mix concrete.	
General infill	-	Insitu <u>or</u> cement stabilised (1:8-12 dry mix ratio) backfill without peat, blue clay, organics and top soil.	Penetration count or manual pressure dial records as required or treated as uncontrolled fill if unsupervised.
	AS 3648	Generic dry mix concrete.	

	AS 1379	20-25 MPa minimum reinforced concrete or plain concrete with plasticiser admixture or fibre mix as required (e.g. upstand crack control).	AS 1012
Insulation layer in drained area and above design flood level. (ingress of fines over the design working period shall be controlled)	AS 2758.1	Washed 20, 28, or 40 mm nominal <u>single</u> size angular or round aggregates.	-

In situ backfill mix composition, the proposed compaction, supervision and testing methodologies for foundation relying on strength of backfill shall be approved by Western Power. Surface infill level and grade shall account for settlement and shall direct water/runoffs away from the foundation.

Pressurised grout may be used to improve in situ soil conditions, the design and methodology shall be approved by Western Power.